

Features

- Complete RF Transmitter
- Transmit Range Up To 50m
- CMOS / TTL Input
- No Adjustable Components
- Stable Operating Frequency
- Low Current Consumption (Typ 4mA @ 3V)
- Wide Operating Voltage (1.5-15v)
- ASK Modulation
- Available as 315 or 433 MHz

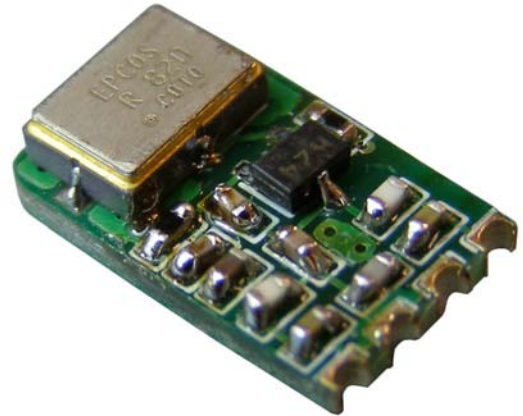

Applications

- Wireless Security Systems
- Garage Door controller
- Remote Gate Controls
- Remote Sensing
- Data Capture
- Sensor Reporting

Description

The Quasar UK AM hybrid transmitter module provides a complete RF transmitter which can be used to transmit data at up to 2KHz from any standard CMOS/TTL source.

The module is very simple to operate and offers a wide operating voltage range, the RF Power output increases in line with the voltage level applied to the module. Data can be supplied directly from a microprocessor or encoding device, thus keeping the component count down and ensuring a low hardware cost.

The modules are compatible with the Quasar UK Ltd. range of AM receivers to provide a complete solution.

Typical Application

For further information on this circuit please refer to the RF Solutions datasheet DS600

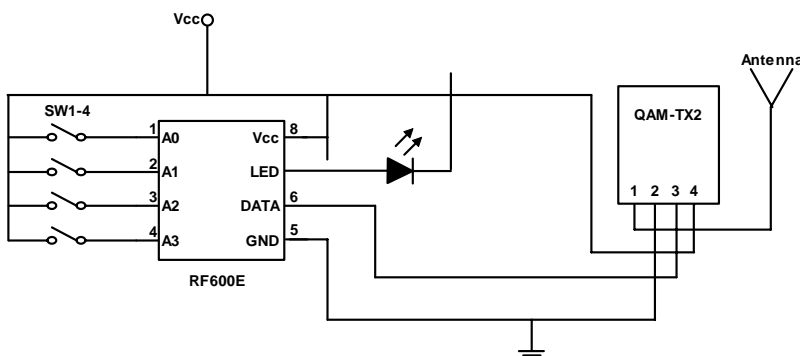

Part Numbers

Part Number	Description
QAM-TX2-433	AM Transmitter Module, 433MHz
QAM-TX2-315	AM Transmitter Module, 315MHz

Technical Specifications

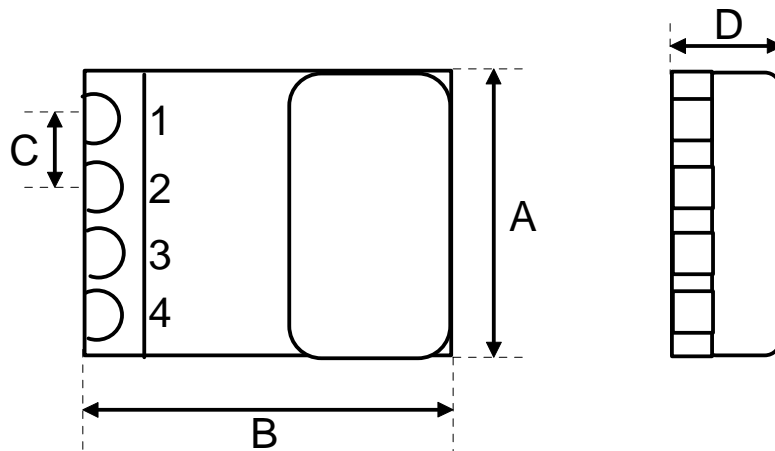

Dimensions

Pin	Measurements (mm)
A	6.5
B	11
C	1.5
D	3

Pin Descriptions

Pin	Name	Description
1	ANT	External Antenna
2	GND	Ground
3	IN	Data input
4	Vcc	Supply Voltage

Electrical Characteristics

Ambient temp = 25°C unless otherwise stated.

Characteristic	Min.	Typ.	Max.	Dimensions
Supply Voltage	1.5	3	15	Vdc
Supply Current (Vcc=3V IN=1kHz)	3	4	5	mA
Supply Current (Vcc=12V IN=1kHz)	17	20	25	mA
Output Power (Vcc=3V IN=1kHz)	0	1	3	dBm
Supply Current (Vcc=12V IN=1kHz)	3	5	8	dBm
Working Frequency		315 / 433.92		MHz
Frequency Accuracy	+/- 75	+/- 150	+/- 250	KHz
Time from Power on to data transmission		20		Ms
Data Rate	200		2,000	Hz
Operating Temperature	-20		+70	°C

www.quasaruk.co.uk

Information contained in this document is believed to be accurate, however no representation or warranty is given and no liability is assumed by Quasar (UK) Ltd. with respect to the accuracy of such information. Use of products as critical components in life support systems is not authorised except with express written approval from Quasar (UK) Ltd.